



# CUI9CRG3E

## CUI 9 CRG3E

- 90 cm Designer Hood
- 3 Speed control
- Exhaust Capacity 1000m<sup>3</sup>/hr
- Halogen lamp
- Metal & Charcoal filters
- Double Turbine motor
- Electronic touch control Panel
- Tempered glass wing with lifetime warranty
- 1030 x 900 x 500 ( H x W x D )

**\$899**

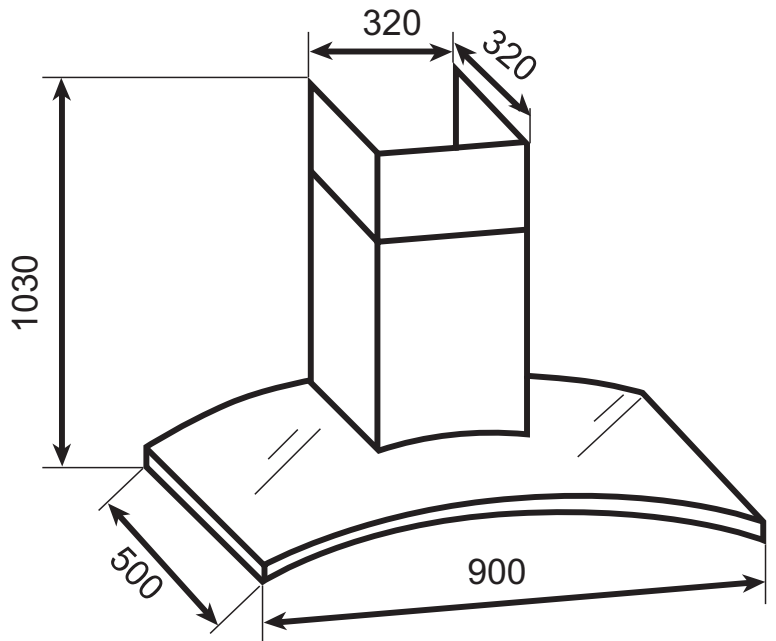

CUI9CRG3E / 042007

Exclusive Distributor



**APS LIFESTYLE MARKETING PTE LTD**

9 Muthuraman Chetty Road, APS Building, Level5, Singapore 238931 • Tel: +65 6233 1333 • Fax: +65 6737 4567 • Email: apsgroup@singnet.com.sg